

ALLIANCE WINDOW COMPANY, INC

Commercial Aluminum Windows & Doors

PRODUCT INFORMATION:
PROJECT IN WINDOW
2000 SERIES INSWING
3-1/4" FRAME DEPTH
MFG CODE: 2100 INSWING
-AAMA CW 100 RATED
180 PSF STRUCTURAL
15 PSF WATER

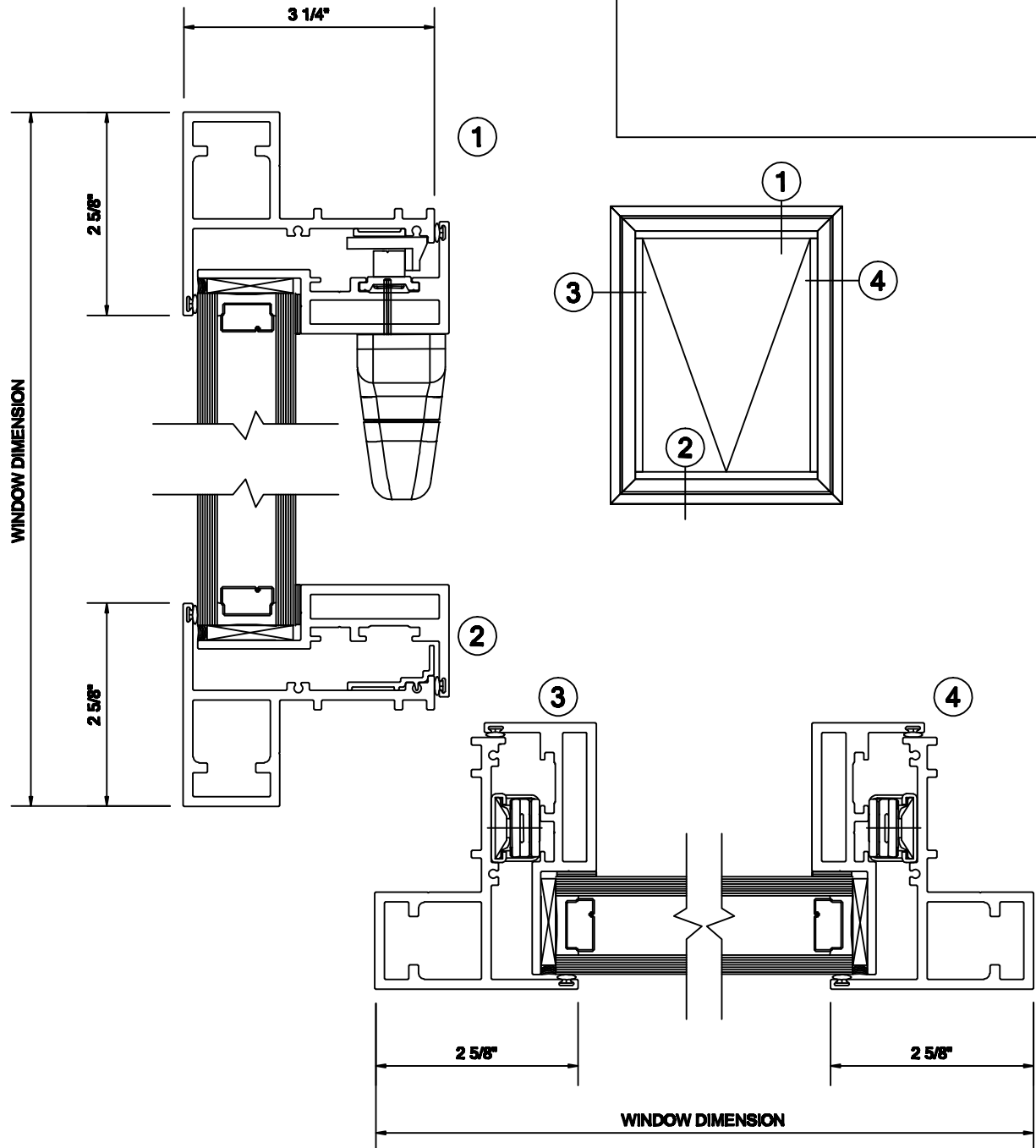

14152 ARNDT ROAD N.E. AURORA, OREGON 97002
PHONE: 503.678.2966 FAX: 503.678.6876 WEB: WWW.ALLIANCEWINDOW.NET